

Structural System Description

The proceeding section contains detailed descriptions of the various structural systems that have been incorporated into the design of the Trump Taj Mahal Hotel. Descriptions of the foundation system, columns, floor systems, miscellaneous systems, and lateral system are provided and follow in that respective order. Figure 6 provides an illustration of the framing plan of a typical level of the tower.

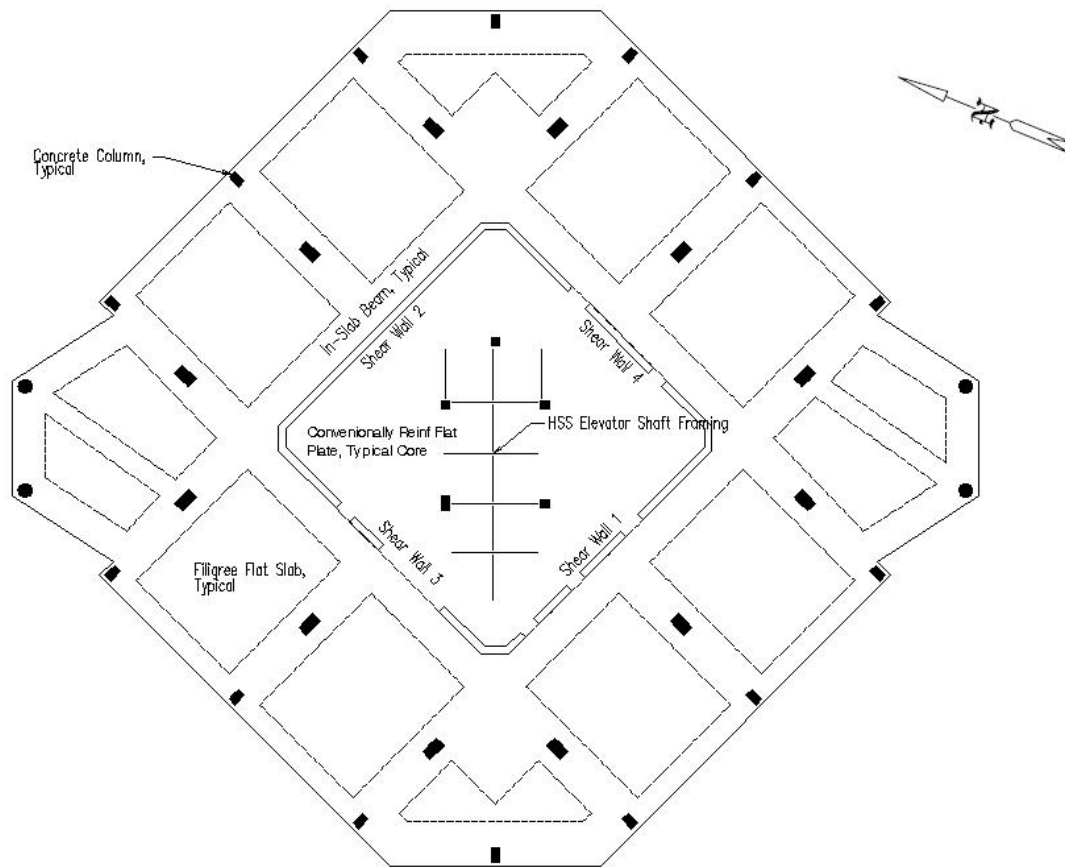

Figure 6: Typical Framing Plan

Foundation System

The foundation system of the Trump Taj Mahal Hotel is comprised of a mat foundation, as recommended by the geotechnical report. The perimeter of the mat foundation is 6'-0" thick, the center 9'-0" thick. #11 bars at 10" each way, top and bottom are provided for the 9'-0" thick section and #11 at 15" each way, top and bottom are provided for the 6'-0" thick section. Additional reinforcing is provided around openings and columns. The mat foundation acts as the floor system of level one, a topping slab is provided.



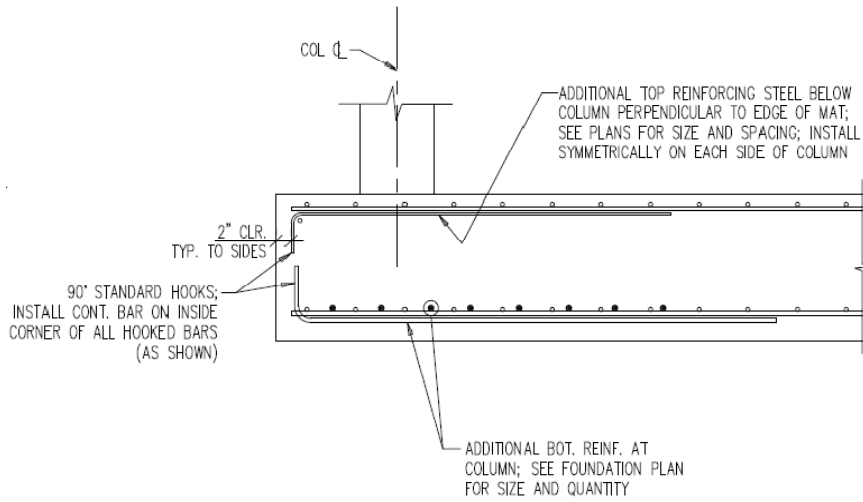

Figure 7: Typical Section at Mat Foundation

Columns

Square, rectangular, and round reinforced concrete columns are used throughout the hotel tower, with a wide range of sizes and reinforcing arrangements. Figure 8 provides a typical detail that illustrates the tie arrangements, vertical reinforcing steel arrangements, and dimensions of the columns that are found throughout the tower. Specified compressive strength of concrete used for the columns varies by level, generally higher at lower levels.

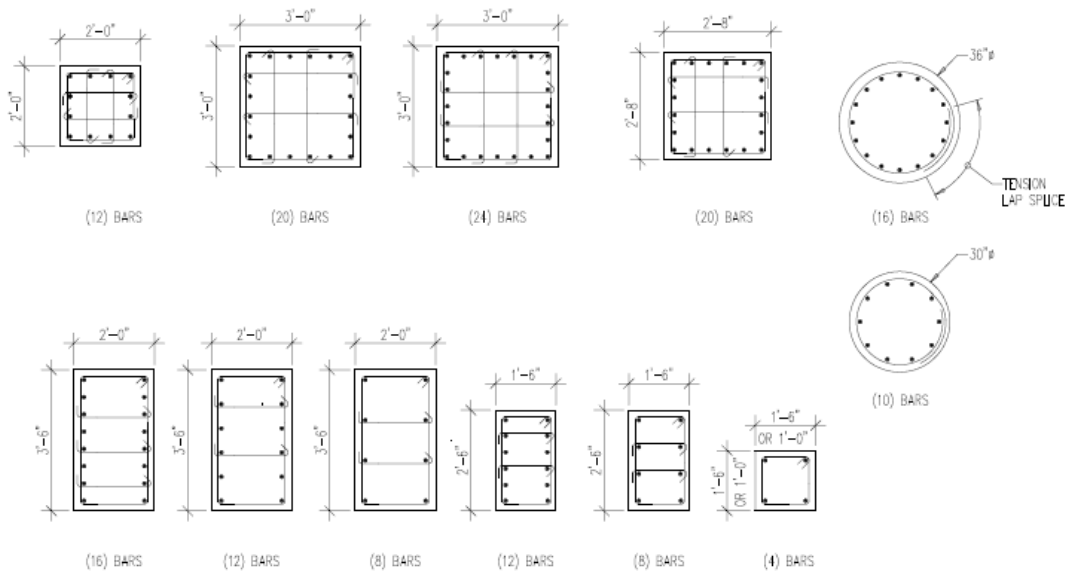

Figure 8: Detail of Typical Column Types



Floor Systems

Two types of floor systems are used on a typical level of the hotel tower. A one-way pre-stressed filigree flat plate system is utilized in the areas outside of the central elevator core. Inside of the core, a conventionally reinforced flat plate system is utilized. 5000psi is the specified 28 day concrete compressive strength of both systems.

A filigree flat plate floor slab acts as a composite system, utilizing both pre-cast and cast-in-place components. 8'-0" wide 2 1/4" thick pre-stressed planks form the base of the system. Foam voids are cast on top of the planks, lowering the dead weight of the system.

However, some floors of the tower with higher loads may have solid slabs instead of voided slabs. A layer of concrete is poured on top of the planks and 2 1/4" on top of the voids, if present. 10x10 W4xW4 Welded Wire Fabric is used as temperature reinforcing for the cast-in-place concrete.

The loads of the filigree flat slab are transferred to the columns via 8'-0" wide conventionally reinforced in-slab beams that run 32'-0" x 16'-0" bays, typically. The filigree flat slabs are connected to the in-slab beams by reinforcing dowels, typically #7 bars on the top layer. The base of the beams are formed using the filigree planks, however the prestressed tendons are not utilized in the design strength of the beam.

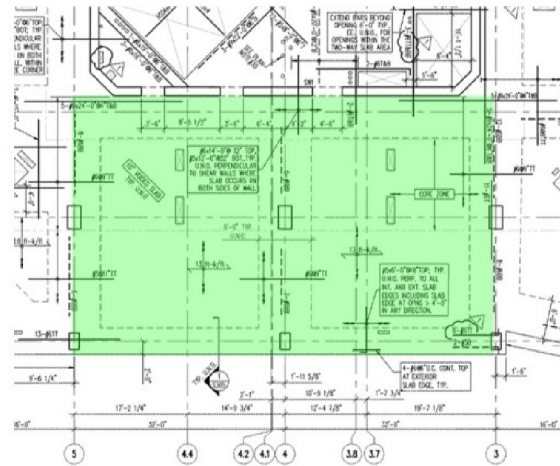

Figure 9: Typical Filigree Bay

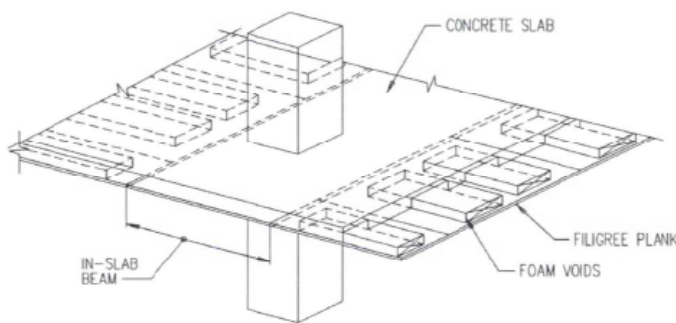

Figure 10: Filigree Flat Plate System



Figure 11: Filigree Construction Photo



Filigree Flat Slab System (Non-Core)

The proceeding diagram describes the various filigree flat slabs, by level number.

Level Number	Solid or Voided	Total Depth (inches)
2, 3	Voided	12
4	Solid	10
5 thru 39	Voided	10
40	Solid	12
41	Solid	10

Table 1: Filigree Slab Properties

Conventionally Reinforced Flat Plate System (Core)

The proceeding diagram describes the various conventionally reinforced flat plate slabs, by level number.

Level	Reinforcing	Thickness (inches)
2, 3	#6 @ 12" Bottom, Each Way	12
4	#7 @ 12" Bottom, Each Way	10
5 thru 39	#6 @ 12" Bottom, Each Way	10
40	#6 @ 12" Bottom, Each Way	12
41	#7 @ 12" Bottom, Each Way	10

Table 2: Conventional Flat Plate Slab Properties

Miscellaneous Framing

Level 3 – Catwalk

A catwalk that houses mostly MEP equipment above level 3 that encompasses the elevator core of the tower is framed using W shape beams. This steel framing is supported by both the concrete shear walls and concrete columns. The steel beams are connected to the concrete using embed plates with shear studs. 2" of bar grating serves as a floor for the catwalk.

Sign Support Framing (Level 41 to Top of Sign)

The Trump sign at the top of the hotel tower is supported by HSS girts, supporting the sign weight of 550plf. Two lines of columns, typically W14x61, post up from the concrete floor system of the 41st level, forming the perimeter lines of the system. Another line of columns, typically W24x68, posts up at the center of the original two lines from transfer girders, making three column lines. W16x67 and W24x68 are the typical girder sizes. There are a total of 7 bays, varying in span length.



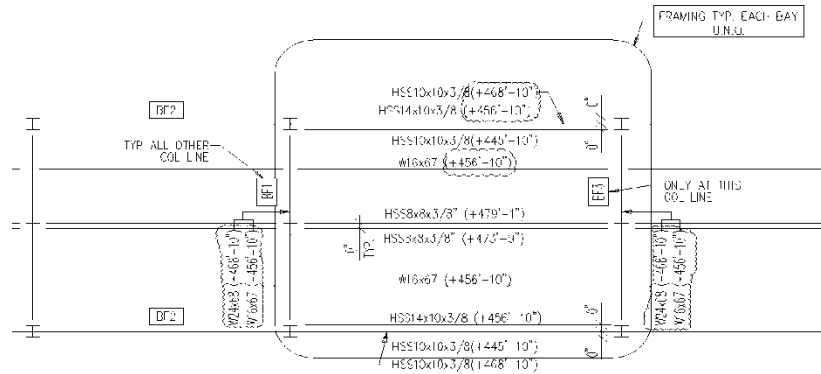

Figure 12: Typical Framing Plan at Sign Support

Elevator Separator/Support Framing

Elevator shafts are separated using a rectangular grid of HSS beams. The HSS beams are also used to resist the thrust force produced by the elevator systems. These beams tie to both the two-way slab floor system and the concrete columns by connecting to embed plates. See Appendix 2 for typical elevator separator beam framing plan.

Connection Bridge

The bridge that connects the existing hotel to the new hotel is framed using a composite steel system with slab on metal deck. The system frames into the vertical elements of the existing hotel tower and two W shape columns outside the perimeter of the new hotel. An expansion joint between the floor slab of the bridge and the concrete slab of the new hotel separates the two systems.

Lateral Systems

The primary lateral force resisting system of the hotel tower is comprised of a cast-in-place concrete shear wall core located at the geometric center of the tower's plan. The shear wall core contains various openings, coupled with concrete beams. A series of braced frames are used to stiffen the sign support structure at the top of the tower.

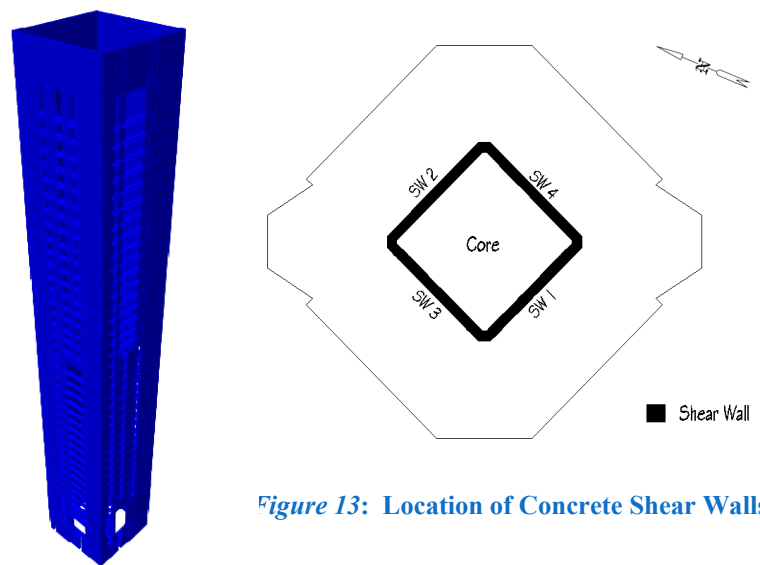

Figure 13: Location of Concrete Shear Walls



Reinforced Concrete Shear Walls

Four shear walls, spanning to level 41, are the primary lateral force resisting system of the Trump Taj Mahal Hotel. Two 60' long walls resist the forces in the east/west direction, as well as the north/south direction. These four walls form the elevator core that lies in the geometric center of the tower.

The shear walls decrease in thickness, 24" from levels 1 through 4 and 16" from levels 4 through 41. Because numerous openings exist, link (coupling) beams provide load transfer across the openings. Specified compressive strength of the concrete used for the shear walls varies by level and decreases from 9000psi to 5000psi; lower to upper levels respectively.

Braced Frames

Because the framing system supporting the large sign at the top of the tower is long and narrow, lateral bracing is needed to stiffen the system against strong wind forces. In the short (north/south) direction, seven X braced frames with single angle diagonals and one single strut braced frame with double angle diagonals.

The long (east/west) direction does not require much lateral stiffening because of its depth. Only two X braced frames with single angle diagonals are provided. The loads of these braced frames are transferred to the concrete floor system on the 41st level below. The concrete floor system acts as a rigid diaphragm, transferring the loads to the concrete shear walls.

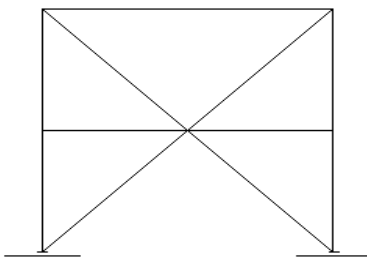

Figure 14: Braced Frame 1

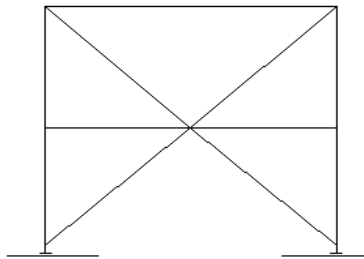

Figure 15: Braced Frame 2

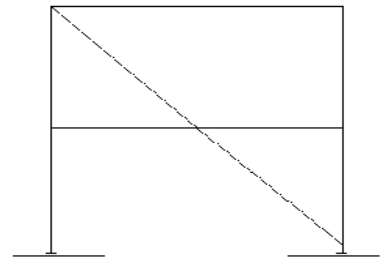

Figure 16: Braced Frame 3

